

Low voltage co-fired multilayer stacks, rings and chips for actuation

(without casing)

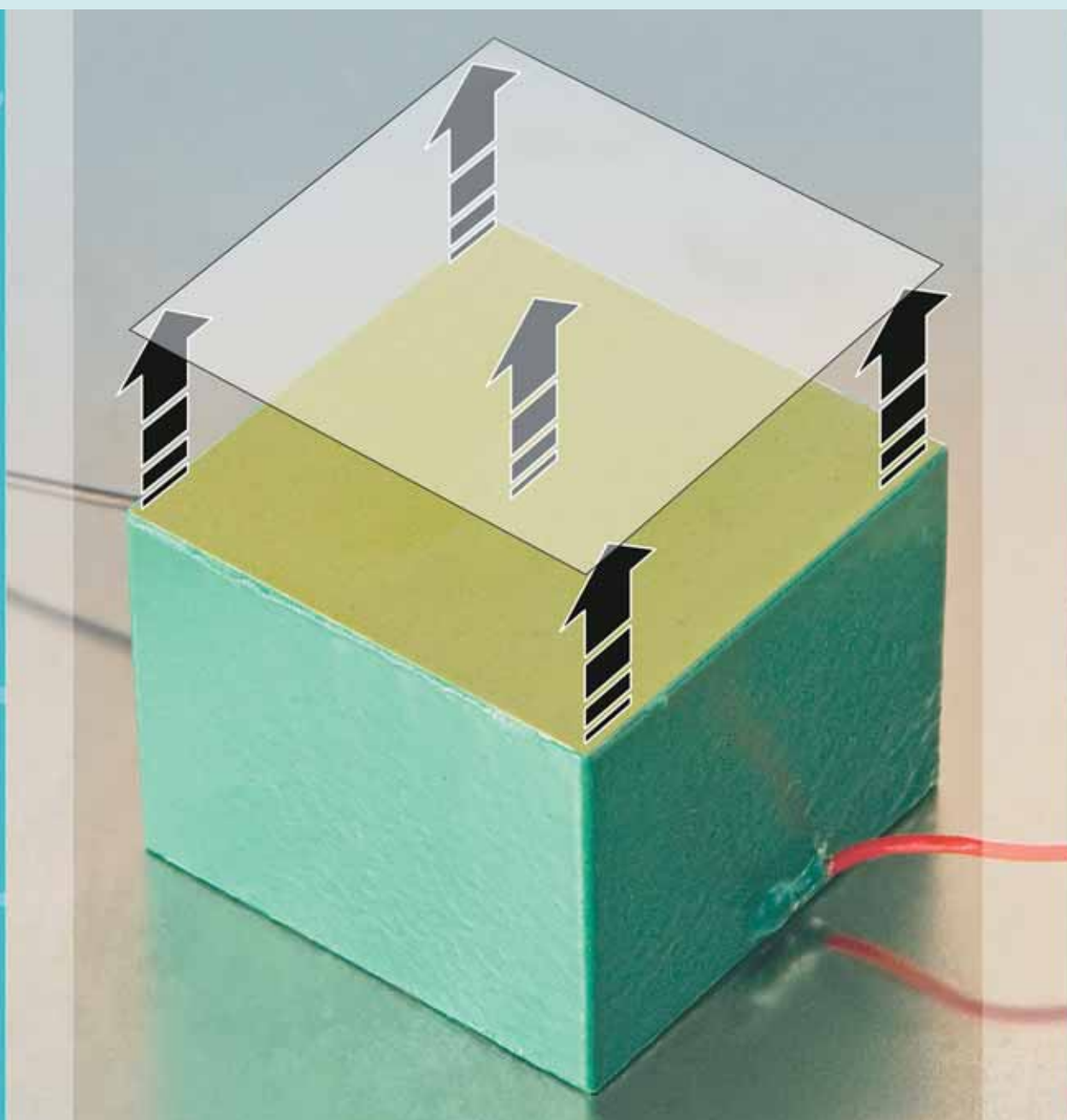

Low voltage actuators with casings, high voltage actuators [Check main catalogue](#)

Piezomechanik GmbH

contents

1.	State of the art of co-fired low voltage actuators	3
1.1	Piezo-stacks with on-stack-insulation (osi)	5
1.2	Piezo-stacks with in-stack-insulation (isi)	7
2.	Aspects of actuator operation	11
2.1	Bulk-stacks or hollow ring-stacks	11
2.2	Mechanics of actuator operation	12
2.3	Mounting advises	14
2.4	Influences from ambient	17
2.5	Electrical operation conditions	18
3.	Products, technical data	20
3.1	Piezo-stacks PSt 150/HPSt 150 (osi-type)	21
3.2	Piezostacks PSt 150hTc with reduced capacitance (osi-type)	24
3.3	Piezo-chips PCh 150/HPCh 150 (isi-type) (with buried electrode design)	26
3.4	Special designed stacks and rings	28

State of the art of co-fired low voltage actuators

1

Piezo actuators are electro-mechanical “motors”, based on the solid state piezo-mechanical deformation effect of piezo-ceramics (*PZT lead [“plumb”] zirconium titanate*). Highlights are unlimited positioning sensitivity (sub-nanometers), high load capability and high force generation resulting in utmost mechanical dynamics with reaction times down to micro seconds. Only piezo actuation allows top innovations in mechatronics like nano-positioning or high pressure common rail fuel injection.



Fig. 1: Variety of different kinds of low voltage piezo-elements

Since more than 20 years so-called co-fired multi-layered piezo-elements are available for low voltage piezo-actuation. The trick is to pile up the alternating ceramic/electrode layers structure in the “green” = soft state of the ceramics and to apply afterwards the high temperature sintering process to get the finished ceramic stack.

Special design steps are needed to get the electrically insulated “capacitor”-structure of actuator stacks and rings.

Two concepts have been developed and are in use since a long time, the “**on-stack-insulation**”-

technique (osi) and the “**in-stack-insulation**”-technique (isi). Even when these techniques seemingly aim only for the electrical configuration of the stacks, there are significant mechanical consequences to performance and reliability of the structure due to the electro-mechanical coupling via the piezo-electric effect. The osi-structure exhibit remarkably advantages in actuator performance and ease of handling compared with other techniques. In terms of quantity and diversity of applications the osi-stacks have the widest distribution at the moment due to their robust and general purpose

1. State of the art of co-fired low voltage actuators

character. Osi-actuators are preferentially used at operating temperatures $< 100\text{ }^{\circ}\text{C}$.

Since a few years, the ultra-fast injection valve actuation ("piezo-injectors") by piezo-stacks gave an additional push to the industrial application of co-fired piezo-elements. Reliable operation at temperatures up to $150\text{ }^{\circ}\text{C}$ is a self-evident must.

Special piezo-stacks have been developed using the isi-stack design together with a special high strain/high temperature PZT-ceramics.

These injector elements are optimized to run in a kind of switching mode with rise-times $< 100\text{ }\mu\text{sec}$ and cycle numbers up to 10^{10} . The development of this technology started in Southern Bavaria/Germany.

1.1 Piezo-stacks with on-stack-insulation (osi)

Among the spectrum of low voltage multilayer actuators, the osi-based elements have found the widest applications. The patent for this technology has expired since a few years. The main step is to use a fine glass filament fused onto the PZT-ceramic stack, where the internal layer electrode comes to surface and shall be separated electrically from the counter-polar supply electrode. The glass filaments are well separated from each other and do *not* form a dense (inflexible) glass layer (Fig. 2).

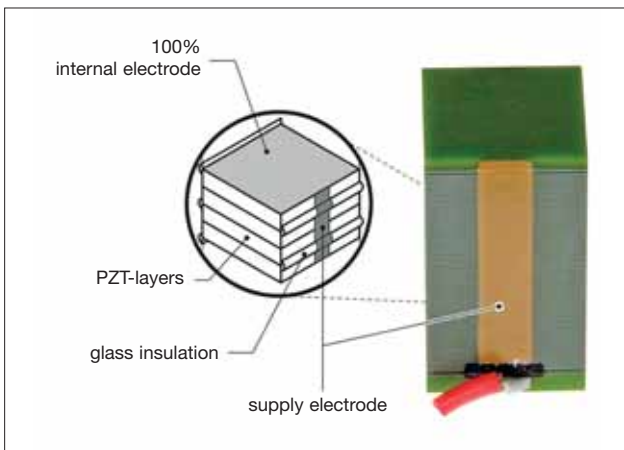

Fig. 2: Schematic of the osi-technique using fused-on glass fibers to terminate internal electrodes on stack's surface

The main highlights of the osi-technique are

- 100% active PZT-ceramic cross-section and stack volume for maximum stroke and force generation (blocking force).
- Homogeneous strain within the PZT-volume, no intrinsic mechanical tensile stress by active/inactive PZT-boundaries resulting in ceramic cracking and electrical break down.
- The absence of intrinsic inhomogeneous stress results in low tilting of the actuator endfaces (useful for coherent-optical arrangements of ring-actuators).
- High electrical reliability:
Osi-actuators show a dense PZT-ceramic surface without side cuts or slots as the isi-technique does. No risk of rupturing the supply electrodes at slots/cuts within the side-faces of the stack.

- Due to the absence of structure borne tensile stress within the ceramics, the osi-stacks can be operated with high strain rates without mechanical preload (as long as no external tensile forces are present).

Surface protection

The sidefaces of standard osi-stacks are coated by polymers.

The coating protects the brittle ceramics against “less” skilful handling, mechanical attack or chemical contamination.



Fig. 3: Different kinds of stack coatings

Special coatings are available to handle exotic driving conditions like cryogenic temperatures, vacuum / UHV, immersion in (non-aqueous) liquids. Polymers are much more flexible than PZT-ceramics and do therefore not affect adversely the piezo-action.

1.1 Piezo-stacks with on-stack-insulation (osi)

On the contrary: A thicker coating acts as a kind of reinforcement and “ruggedizing”, making the stacks less sensitive to bending or tilting forces than an uncoated ceramic stack (Fig. 4).

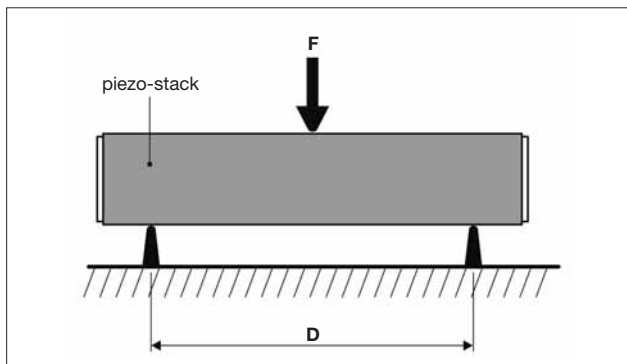

Fig. 4: Schematic of a bending experiment

A piezo-stack PSt 150/2x3/20 with a ceramic cross-section of 2 x 3 mm has been bended by a force F (distance D of the supporting points: 15 mm, bended stack's dimension: 2 mm).

The coated ceramic stack withstands a force F of **80 Newtons** before breaking, whereas the uncoated stack can bear only **38 Newtons!**

Standard coated stacks show a better resistance to a less skilful handling or sub-optimum mechanical designs. Bending oscillations of longer stacks with a critical ratio of length/cross-section are damped away.

Osi-Technology is used by PIEZMECHANIK for the piezo-stacks and rings PSt 150/HPSt 150.

1.2 Piezo-stacks with in-stack-insulation (isi)

The isi-piezo-stack design is a more simple insulating strategy, well-known since the early days of low voltage actuation in the 70ies of the past century. The necessary electrical insulation step is done inside the stack: The PZT-layers are *not* completely metallized. A small insulation gap ensures the electrical separation between the internal electrode and the external supply electrode (Fig. 6).

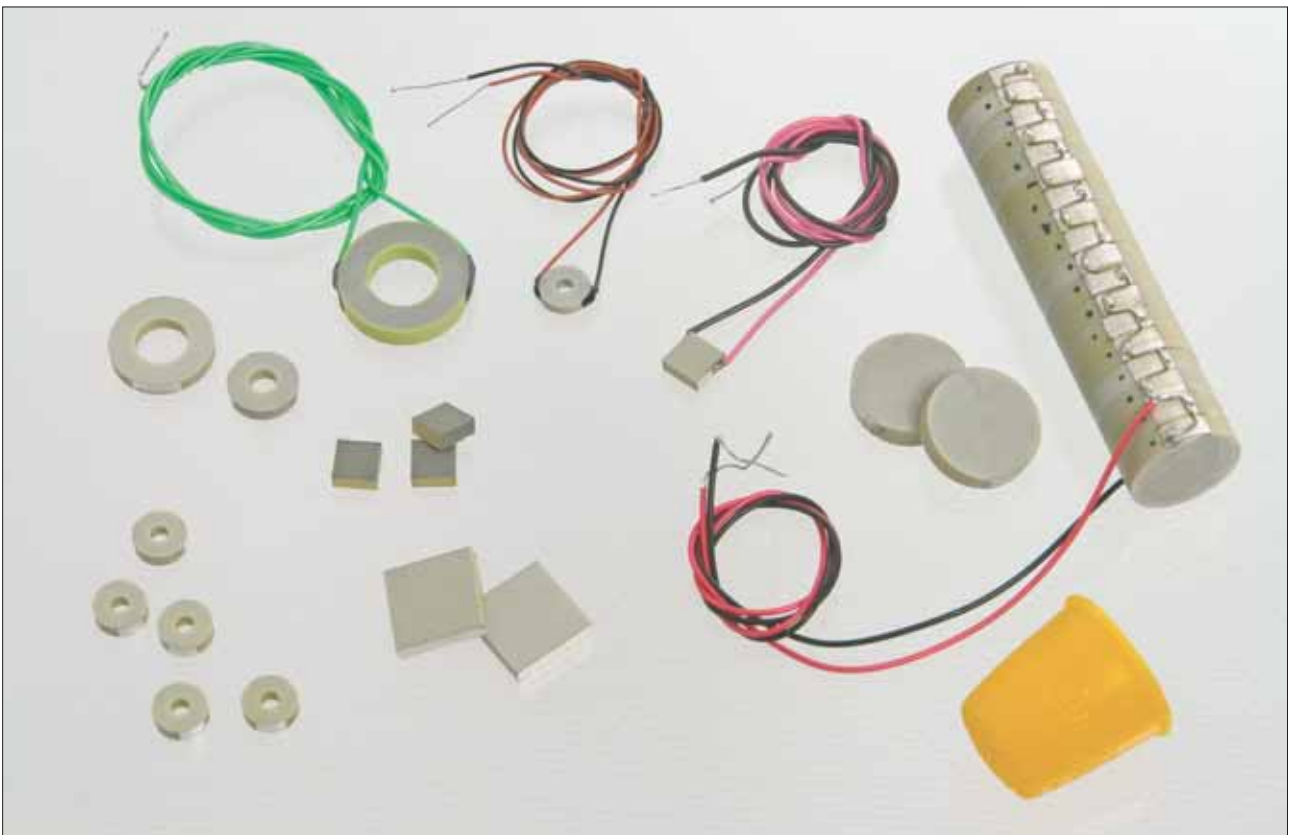
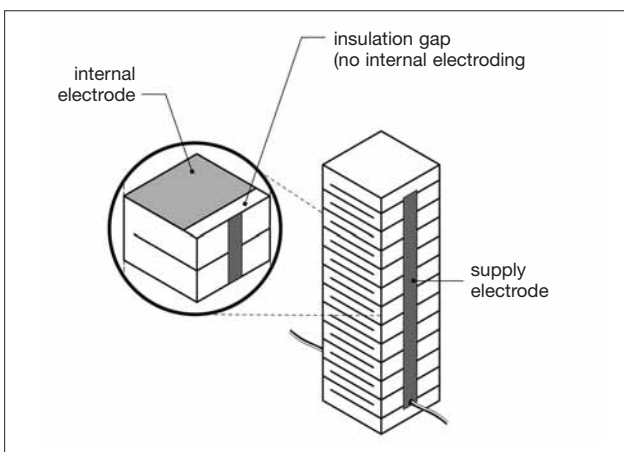

Fig. 5: Isi-actuators in different Execution



It is easily seen, that the PZT-ceramic of the stack is only partially active and a steep transition from active to inactive PZT-ceramic is created: A pronounced mechanical tensile stress at the active/inactive boundary region occurs, when the PZT-stack is activated and expanding (Fig. 7).

Fig. 6: In stack insulation scheme.

1.2 Piezo-stacks with in-stack-insulation (isi)

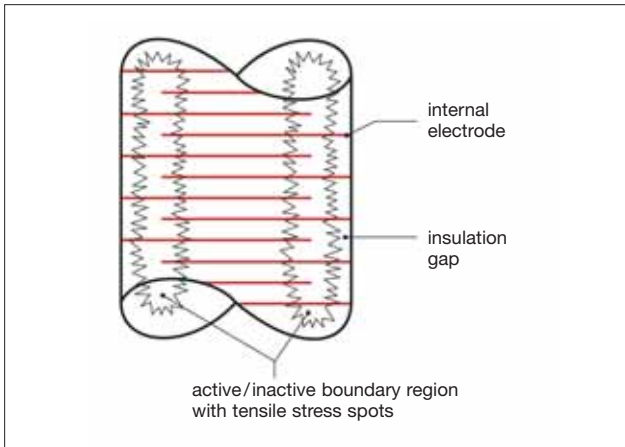

Fig. 7: Mechanical stress generation inside a isi-piezostack at the active/inactive boundary

This leads potentially to mechanical cracking of the ceramic and electrical break down of the stack during long-term action, when potential crack propagation is not compensated for by special techniques.

A Limitation of thickness of the monolithic multi-layer package.

No cracking of the ceramic occurs for rather thin elements. This means: When the axial thickness of the multi-layer element is held within 2-3 mm ("Piezo-chips").

Longer stacks are manufactured by gluing of such monolithic piezo-chips (Fig. 8). The glue-lines between the chips provide stress relaxation. The mechanical properties of such stacks longer stacks depend to some extent on the quality of the glue-joints.

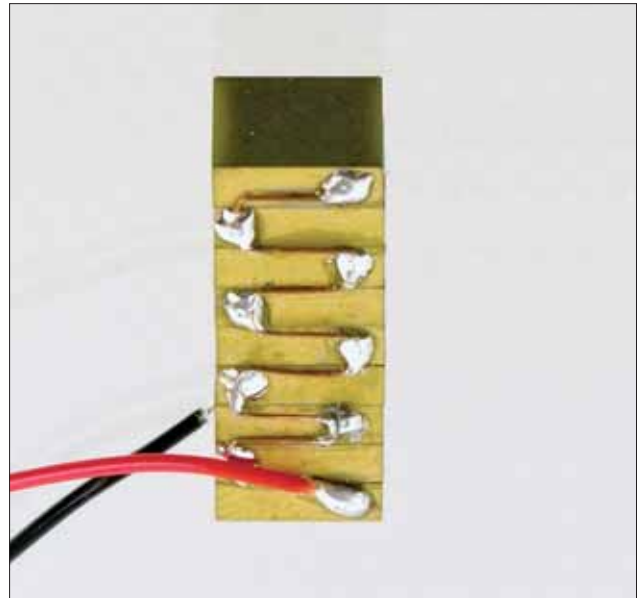

Fig. 8: Chip-based piezo-stack

1.2 Piezo-stacks with in-stack-insulation (isi)

B Stress reduction by expansion joints

For producing monolithic multilayer-stacks with lengths > 3 mm, slots are prepared into the ceramic parallel to the PZT-layers in the critical active/inactive ceramic section (Fig. 9).

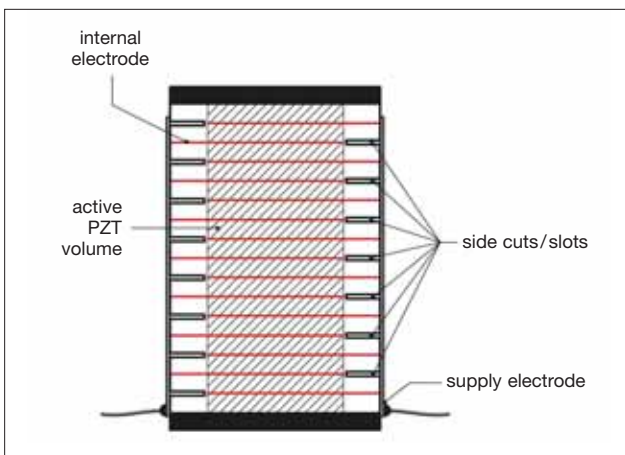

Fig. 9: Isi-based stack with stress relaxation side slots

The isi-structure with side slots is more sensitive to bending forces, because the notches act as starting point of ceramic cracking (Fig. 10).

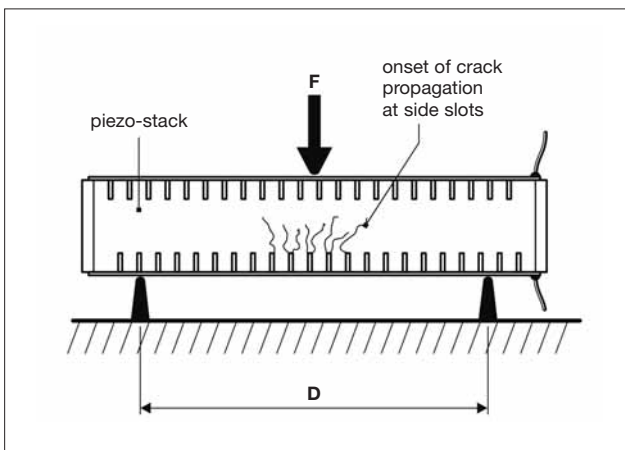

Fig. 10: Bending-induced ceramic cracking of isi-stacks with side slots

The designs of any coupled mechanics has to be optimized for strict axial loading of isi-stacks. Attention should be paid to any mechanical influences resulting in bending modes especially of stacks with large ratio of length/diameter.

C Mechanical preloading

In addition to the above-mentioned techniques, the internal stress-problem of isi-actuators is usually handled by the application of a large axial preload or prestress even for static or low dynamic applications.

D Rupturing of supply electrodes

The supply electrodes of isi-structures must bridge the side slots/cuts in the stack structure. For simple arrangements, the side electrodes tend to rupture in the vicinity of the side slots, when the stacks are operated with high strain and dynamics. The actuator will be deactivated then. The optimum of highly reliable side electrodes is achieved by using metal mesh. (The osi-techniques does not need such strategies simply due to the absence of the side cuts/slots).

1.2 Piezo-stacks with in-stack-insulation (isi)

Surface protection techniques, buried electrode design.

Isi-stacks can be coated with polymers for surface protection in a similar way as described for the isi-systems.

An alternative is the buried electrode design well-known since the early days of low voltage actuation: Nearly the complete circumference of the PZT-stack's cross-section is kept free of any metallization (except the small contact section towards the supply electrode) (Fig. 11).

By burying the internal electrode no additional coating is needed to prevent electro-corrosion when the stack comes to a contact with contaminants. But this is to the cost of an additional reduction of the active PZT-cross-section together with an extension of the inactive/active PZT-boundary problem.

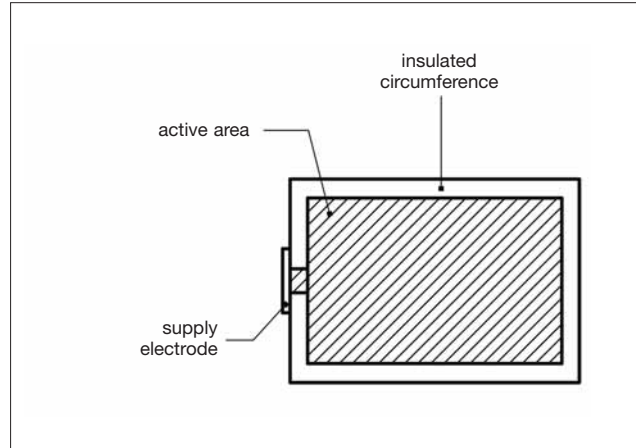

Fig. 11: "Buried electrode" scheme

Aspects of actuator operation

2

2.1 Bulk-stacks or hollow ring-stacks

Ring-actuators are stacks with a centre-bore. It is self-evident, that such a design allows smart and elegant design solutions, when the centre axis of a piezo systems shall be accessible for mechanical, electrical, optical or other purposes.



Fig. 12: Massive stack actuator and hollow cylindrical ring-actuator

Beside these design aspects, the use of rings has distinct piezo-mechanical operation advantages compared to solid stacks: Assuming the same piezo-ceramic volume (defined by equal active ceramic cross-section and length) for a stack and a ring-actuator under comparison, the electrical capacitances and power consumption are the same.

But a ring-actuator shows a

- higher bending stiffness due to the increased actuator diameter
- lower self-heating temperature level, when operated dynamically.

The ring-actuator shows a larger surface (inner and outer circumference) for a better heat transfer to air.

Example

A massive stack actuator PSt 150/7x7/20 shows a similar piezo-ceramic volume like the ring-actuator HPSt 150/14-10/12.

For identical electrical driving conditions, the power consumption and energy dissipation is the same. It has been evaluated, under what cycling frequency both kinds of actuators heat up to 80 °C, when running in ambient air at room temperature.

Result

Stack-actuator PSt 150/7x7/20: **240 Hz**

Ring-actuator HPSt 150/14-10/12: **440 Hz**

The ring-actuator shows remarkable advantages in heat management due to the larger specific surface. By forced cooling/heat-sinking/immersion in cooling liquids, ring-actuators can run full stroke up to the kilohertz range.

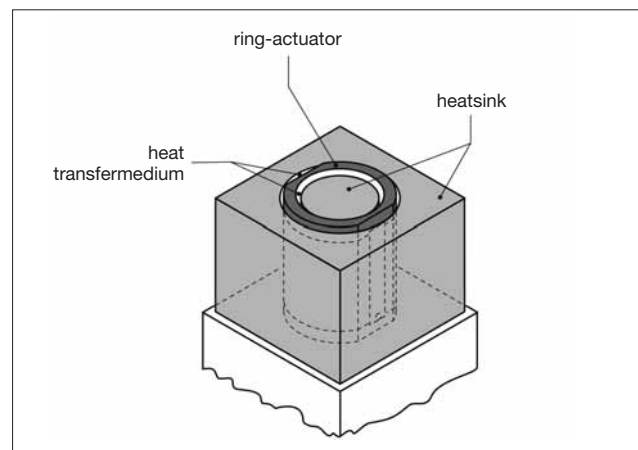

Fig. 13: Scheme of highly efficient ring-actuator cooling by inner and outer heat-sinking

2.2 Mechanics of actuator operation

The handling of piezo-actuators during mounting and operation is ruled by the specific mechanical properties of ceramics like brittleness, low tensile stress damage threshold on one side and its sensitive electrical structure on the other side.

Stack type actuators are mechanically coupled only via the end faces e.g. by clamping, gluing or other methods. The end-faces are electrically insulated, so metal parts can be coupled directly to the stack.

No mechanical contact/impact shall be applied to the side faces.

The side faces bear the supply-electrodes to contact electrically the internal layer electrodes of the capacitor structure. The supply electrodes are wired by pig-tails near the actuator socket. Standard actuators PSt 150 are finally coated with a high quality polymer and are therefore more resistant to mechanical and other influences than bare ceramic components.

Piezo-stacks can bear high compressive load forces, but they are very sensitive to bending-, torsion-, shear-forces and especially to tensile forces. Attention has to be paid to this fact not only during the final operation of such stacks, but during all handling and mounting steps in advance to operation.

The design of any attached mechanics shall aim for pure axial loading of the actuators without any compromise. Imperfect solutions can lead to strongly reduced performance and reliability.

Pay attention not only to the static force balances, but also to dynamic influences (acceleration forces resulting in bending motion or torque).

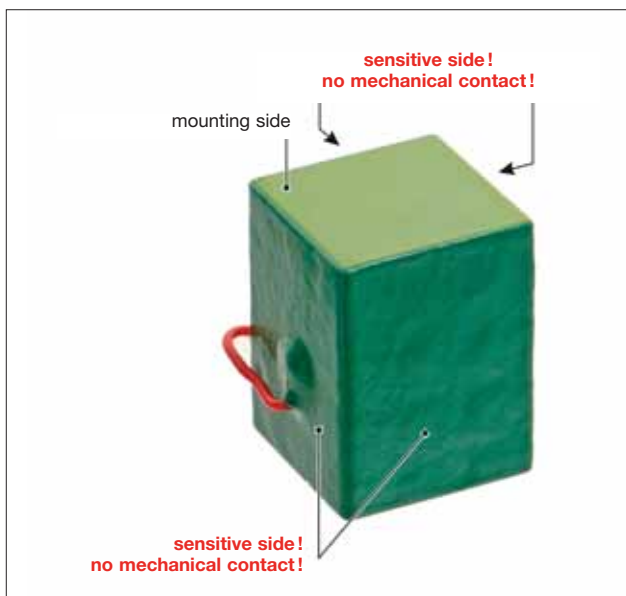

Fig. 14: Mounting scheme of piezo-actuators

2.2 Mechanics of actuator operation

Mechanical preloading:

Preloading is achieved in most cases by using an elastic spring for resetting the moving part of an actuator.

Mechanical preloading of piezo ceramics is necessary to allow a push-pull-operation of an actuator. This is to handle externally applied tensile forces caused by static or dynamic driving conditions. With isi-type actuators, preloading compensates further for intrinsic tensile stress-phenomena as described in section 1.2.

A properly designed mechanical preloading of actuators reduces further microscopic tilting of the actuator end-faces. Coherent optical arrangements like tuneable etalons/resonator structures do not need then additional guiding mechanism for shifts in the micro-meter range.

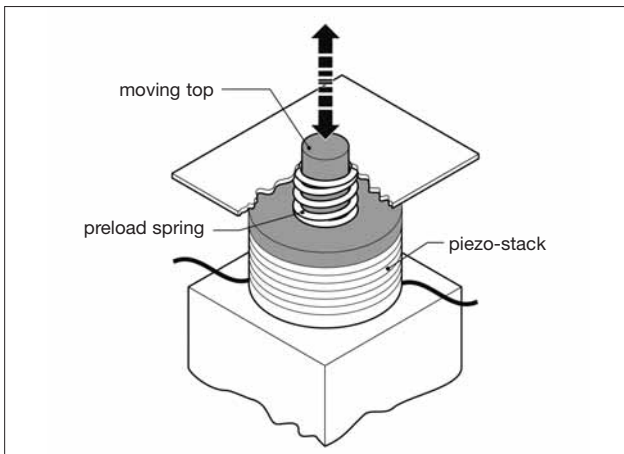

Fig. 15: Schematic of a preload spring mechanism

Preload forces can be high as 50% of the load capability of actuators or even more, to handle extreme driving conditions (e.g. pulsed operation or symmetrical push-pull arrangements).

The “golden rule” of preloading:

Use preload springs of lowest possible stiffness (large compliance).

A good attempt is to select for a spring’s stiffness in the % range of actuator’s stiffness.

Then, no loss of stroke will occur even when high preload forces are applied.

(details: See “force generation” in main catalogue)

Operating stack actuators with reduced strain

Regarding stroke, a beginner in piezo actuation usually seeks for an actuator type, what’s maximum rating stroke covers rather exactly the needed range. This implies consequently, that this actuators is operated up to maximum voltage, maximum electrical field strength, maximum strain and thereby for dynamic applications with maximum power consumption and power losses.

The use of an “oversized” longer actuator can have a lot of advantages compared to the above mentioned “maximum ratings” operation:

- The long-term reliability is improved by the use of reduced electrical field strength (driving voltage \ll max. voltage rating).
- The reduced mechanical strain results in a lower power consumption and self-heating. Vice versa higher oscillation frequencies can be achieved by applying the same power as with the maximum rating type actuators.
- Power supplies with reduced output voltages can be used, providing higher currents (\Rightarrow higher actuator oscillation frequency) and lower costs.

This reduced strain strategy finds its limits, when higher resonance frequencies, stiffness are a must or the stack length is restricted by space limitation.

2.3 Mounting advises

The achievable performance and reliability of an actuator must be seen always in context with the interaction with the operated mechanical system and the electrical driving characteristics.

Poorly designed mechanics like low stiffness coupling to the actuator, friction, wrong preloading, wrong force coupling, misalignment of coupling faces from actuator to mechanics reduce significantly usable stroke, accuracy, force generation and make the use of piezo actuator more or less worthless. Poor designing impact further actuator's long-term reliability.

Fig. 16 shows the consequences of inhomogeneous high force loading: A stack with excessive edge squeezing/pressure of the ceramic-stack by an improper force coupling (Fig. 17 b, c). Cracks are generated within the active ceramic section resulting in electrical break down and arcing.

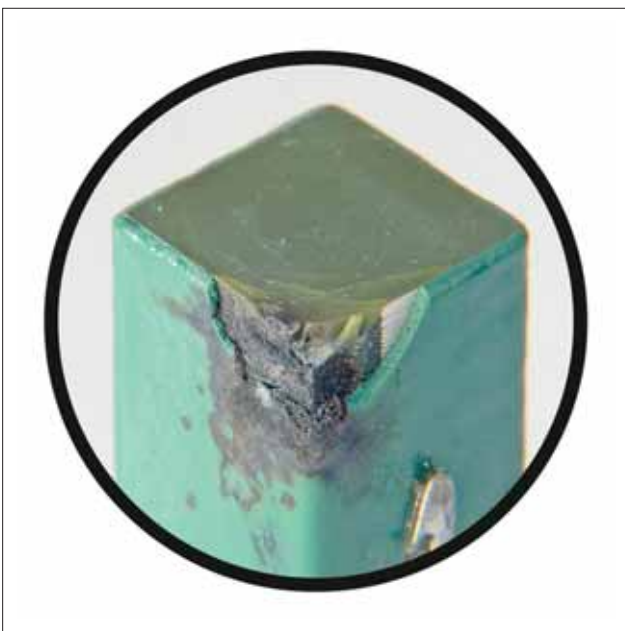

Fig. 16: Failed actuator stack, caused by a wrong coupling to the actuated mechanics. Local edge pressure exceeded ceramic's stability with subsequent electrical break down after approx. 800 hours.

Coupling of actuator and mechanics

Optimum actuation performance is achieved by following a few simple rules

- The coupling face of the mechanics shall cover completely actuator's end faces to achieve maximum force transfer (Fig. 17 a). The contact force shall be homogeneously distributed over the contact area.
- When a high load pressure is applied, the coupling faces of actuator and mechanics faces shall be absolutely plain (eg. by grinding) to avoid local overload of the ceramic front face.
- The resulting load force vector shall coincide with actuator's axis. Within a virtual cylinder of +/- 10% of actuator's cross-section (Fig. 17 a) to avoid excessive bending and shear stress. Force misalignment tolerance α becomes more critical for increased ratios actuator length / diameter. For high dynamic operation, actuator's axis shall further hit the centre of mass of the attached mechanics to avoid dynamic torque.

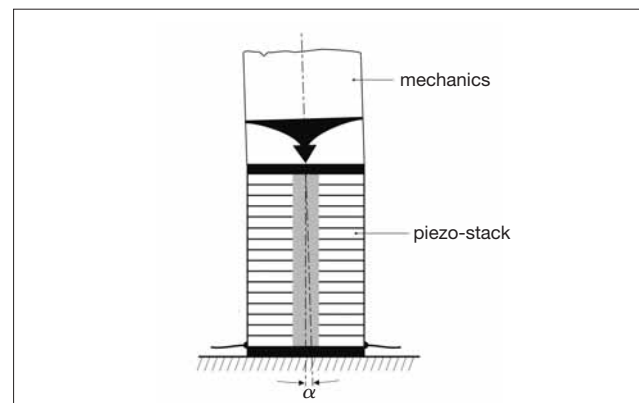

Fig. 17 a: Perfect plain-plain coupling of piezo-stack and attached mechanics by floating axis orientation of the mechanics. Acceptable tolerance α : See above

2.3 Mounting advises

- When the mechanical partner can read just itself by a free suspension (floating axis) according actuator's plane face, no problems will occur.
- Coupling of piezo actuators to guided mechanisms (axis orientation not floating). One of most widespread design mistake is coupling a plain-faced actuator directly to a plain-faced guided mechanism (Fig. 17 b) Even the slightest misalignment between the orientations of the both plains leads immediately to edge squeezing with very high local spot pressures and subsequent ceramic damaging (Fig. 16), especially under high force load conditions.

In a similar way, the plain-plain coupling of an axially acting stack with a rotating lever arrangement will lead to a fundamental edge squeezing situation in any case (Fig. 17 c). Do not try this!

In the above cases, it is a must to decouple the axis orientations by using spherical / plain coupling or flex hinges or other means!

- The above requirements are valid at any time and any state of the system during set up and operation.

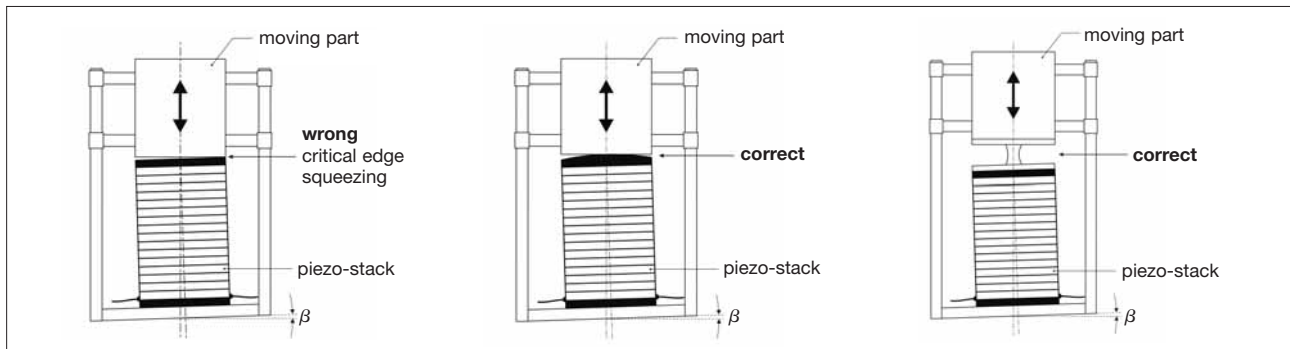

Fig. 17 b: Incorrect/correct coupling of linear guided mechanics

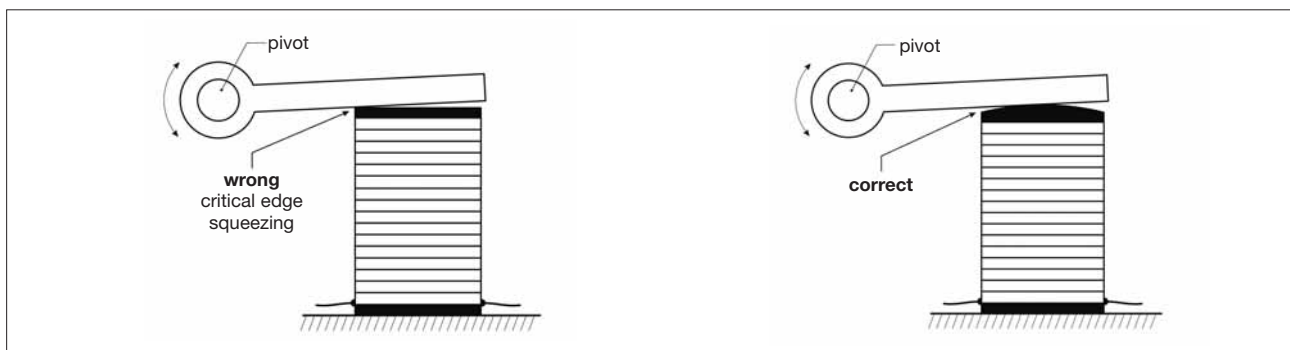

Fig. 17 c: Incorrect/correct coupling of a rotating mechanism

2.3 Mounting advises

Bonded contacts piezo-stack/mechanics

The contact between actuator stack and mechanics /actuated components is often done via gluing. The basic considerations about the contact quality with respect to alignment remain valid: Misalignment of the joined parts as shown in Fig. 17 b, c results in strong bending forces and tensile stress within the piezo ceramics reducing both performance and reliability.

The only compromise for gluing can be made with respect to the flatness of the mechanical part, because the adhesive has to some extent a “filler” property.

For applications within a range of $-20\text{ °C}/+60\text{ °C}$, any good quality epoxy can be used. The cure temperature shall be held rather low to avoid thermally induced stress, when the CTEs of the joined parts is remarkably different. The thickness of the glue lines shall be held rather thin ($< 50\text{ }\mu\text{m}$) to avoid a “softening” of the coupling quality. For “exotic” driving conditions like very low or very high temperature, vacuum application etc. special adhesive formulations and gluing techniques are recommended. Ask PIEZOMECHANIK for support.

Piezo-chips

On the other hand too hard and too thin glue-lines increase the “ d_{31} -clamping” effect, what can hinder or block the axial motion especially of piezo-chips (Fig. 18 a, b, c).

For coherent optical applications, unwanted tilting of mounted optical element will then occur. Further, thin optical elements can be distorted by a hard coupling to a piezo-chip (bending structure).

Only when the d_{31} -planar contraction is not hindered, a thin piezo-chip will show the maximum axial d_{33} -expansion and planar displacement.

Ask PIEZOMECHANIK for more details. A special brochure will be provided on request.

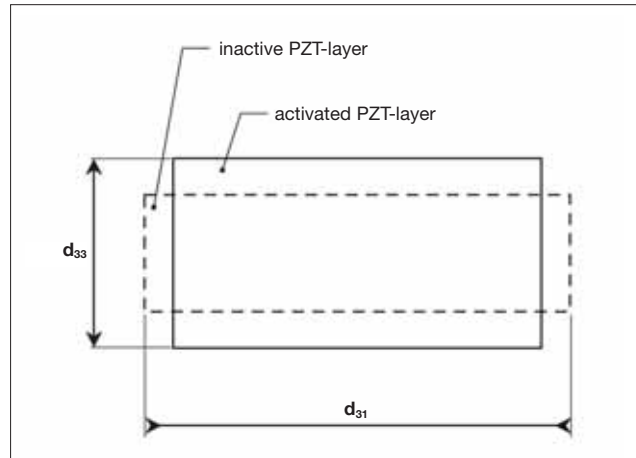

Fig. 18 a: Action of a free PZT-layer

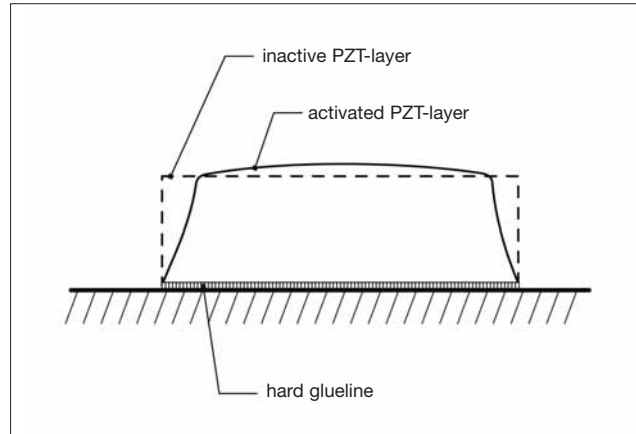

Fig. 18 b: Hindered expansion of a PZT-layer by clamping by a hard glue line together with a rigid substrate

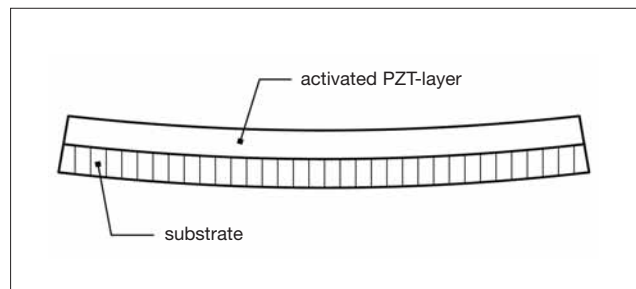

Fig. 18 c: Bending structure by gluing a PZT-layer onto a thin substrate.

2.4 Influences from ambient

Piezo stacks are electrically highly active elements with high electrical fields at stack's surface.

For mounting stacks into metal constructions, ensure sufficiently large insulation gaps between stack's side-faces and the surrounding mechanics. A PZT-stack-structure is rather sensitive to any contamination by conductive species like electrolytes. Leakage currents will set on, leading to electro corrosion and subsequent short circuiting of the actuator. Contact to aqueous liquids shall be avoided.

On the other hand stacks with polymer coating can be operated within non-aqueous fluids (e.g. Diesel fuel, transformer oil, silicon oil), what can be used for high efficient cooling of dynamically operated stacks.

Do not touch bare stacks with bare fingers. Cleaning of coated and uncoated stacks shall be done only with 100% iso-propanole. Never use acetone!

PIEZOMECHANIK's PSt 150 osi-actuators are world-wide in use since decades, running successfully with highest reliability under widest variety of applications for very different driving conditions with direct access to ambient atmosphere.

Experience shows, that only for a very high humidity loading of the ambient atmosphere ("tropical"

conditions) in context with long-term applied maximum voltage additional measures are required to ensure high reliability.

These effects can be overcome by incorporating the stacks into hermetically sealed casings or by applying tightly a pinhole-free metal-foil to actuator's surface as humidity protection. Metal foil encapsulated osi-samples (Fig. 19) are running since 2 years at 150 V DC/85% rel. humidity at 20 °C without any degradation.

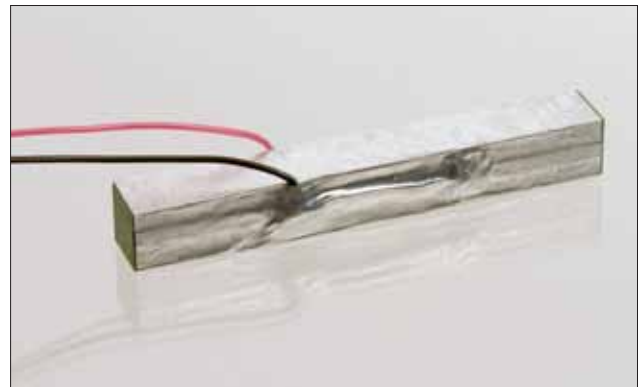

Fig. 19: Metal foil encapsulation of a PZT-stack

2.5 Electrical operating conditions

Voltage ranges, polarity:

Piezo-actuators are poled components. Usually, the positive pole is indicated e.g. by

- A** red pigtail wires
- B** printings, dots
- C** long wire

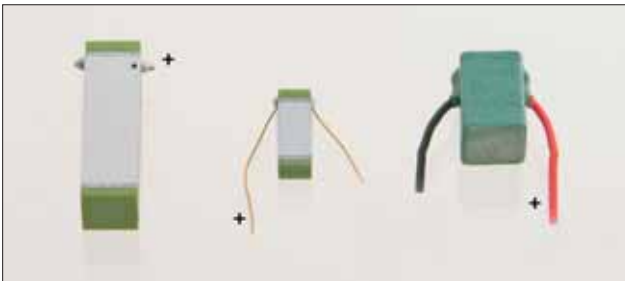

Fig. 20: Actuator's poling

In the following

- (+) indicates a polarity of the applied voltage parallel to actuator's poling, whereas
- (-) means a counter polarity, opposite to actuator's poling.

The piezo mechanical data like **stroke** and **blocking force**/max. force generation depend on the applied voltage levels.

The maximum ratings of stroke and force are defined for uni-polar or semi-bipolar operation as follows

- **Unipolar mode e.g. 0 V/(+)150 V**
- **Semi-bipolar operation e.g. (-)30 V/(+) 150 V for stacks and chips PSt 150.**

Due to the larger voltage swing, the semi-bipolar operation offers potentially larger strokes and force generation (blocking force) than the uni-polar mode. PIEZOMECHANIK offers the semi-bipolar amplifiers SVR to get maximum stroke and force generation (blocking force) from a stack-actuator.

The stated actuator voltage ranges shall not be exceeded.

A short term overpowering of the upper (+) voltage limit of a multilayer-structure by 10% does not immediately result in a break down, but the reliability is strongly reduced by time. Still higher voltages go the risk of immediate arcing and electrical break down.

2.5 Electrical operating conditions

Using too high counter-voltages (below the (-) limit of the semi-bipolar range) implies the risk of de-poling the PZT-ceramics. Attention must be paid here to operation at elevated temperatures, what lowers potentially the de-poling stability.

The 150 V-osi-Actuators PSt 150 are easy to handle with regard to de-poling: By applying for a few seconds a voltage of about 100 Volts, the ceramic will be reactivated completely without any losses in performance.

The isi-actuators and Piezo-Chips are more critical: On one side they show higher temperature stability by a higher Curie-temperature of the PZT-ceramic, but in case of de-poling or polarity-reversal, the actuator properties can change irreversibly.

The risk of oversized amplifiers is the high acceleration force, what will be created, when a transient interference signal is picked up. When the actuator system is not adapted to such high accelerations, the actuator will be damaged.

Oversized amplifiers are costly and may show additional disadvantages like elevated noise levels.

1. Rule of thumb: Use only power supplies with voltage ranges matched to the actuator ratings.

Power consumption, current levels:

Piezo-stacks behave like capacitors in the sub-resonant frequency range.

Therefore, a current flows only during a voltage variation for altering the position and/or force status of an actuator. The faster the variation is the higher are the required currents.

2. Rule of thumb: Define precisely the electrical current or power level to get the required dynamics of your actuating system (rise-/fall-times, see brochure "electronics").

Do not oversize significantly the max. current and power ratings of the used amplifier.

Contact PIEZOMECHANIK for selecting well-matched electronic driving systems.

Piezo-stacks/rings PSt/HPSt 150 with superior isi-technology:

- For highest efficiency, reliability and ease of handling.
- Covering nearly all actuator applications ranging from static to highest dynamic operation profiles.
- High mechanical stability and tight tolerances of dimensions and piezo-mechanical data highlight these actuator as OEM-components for industrial use.

Piezo-stacks PSt-HD 200 in special isi-configuration

- For highly dynamic applications at elevated temperature levels

Piezo-chips PSt 150 with active thicknesses up to 3 mm with isi-technology and buried-electrode design

High axial resonance frequencies suitable for sensor/generator applications

- Very low voltage 50 V type with
- Very high charge generation available (energy harvesting)

General remarks on technical data:

Voltage ranges (see chapter 2.5)

- (+) U_{\max} maximum operating voltage according actuator's polarity
- (-) U voltage polarity opposite to actuator polarity

Strokes

Maximum ratings defined for semi-bipolar and uni-polar driving voltage e.g. for PSt 150: 0 V/(+)150 V and (-)30 V/(+)150 V

Capacitances

- Measured at low field excitation at room temperature
- Manufacturing tolerances up to +/- 20%
- Capacitance can depend on high field excitation and temperature

Resonant frequencies

- Refer to axial mode
- Defined for one side fixed piezo-element (other modes like planar diameter not taken into account)

Stiffness

- Inverse compliance,
- measured at short circuited elements or under voltage control operation
 - measured with a static preload of at least of 10% of actuator's maximum load

Blocking force

Means maximum force generation of an actuator
Depends on the applied voltage variation
Stated values refer to maximum semi-bipolar operation.
Maximum uni-polar operation gives about 30% lower values

Maximum compressive load

Maximum constant load range, where actuator's properties are not reduced.
Overload with risk of mechanical damage occurs only for much higher force levels or for very large ratios length/diameter (bending).
Attention has to be paid to avoid local overload of actuator's end faces (see chapter 2.3).

3.1 Piezo-stacks PSt 150 / HPSt 150 (osi-type)

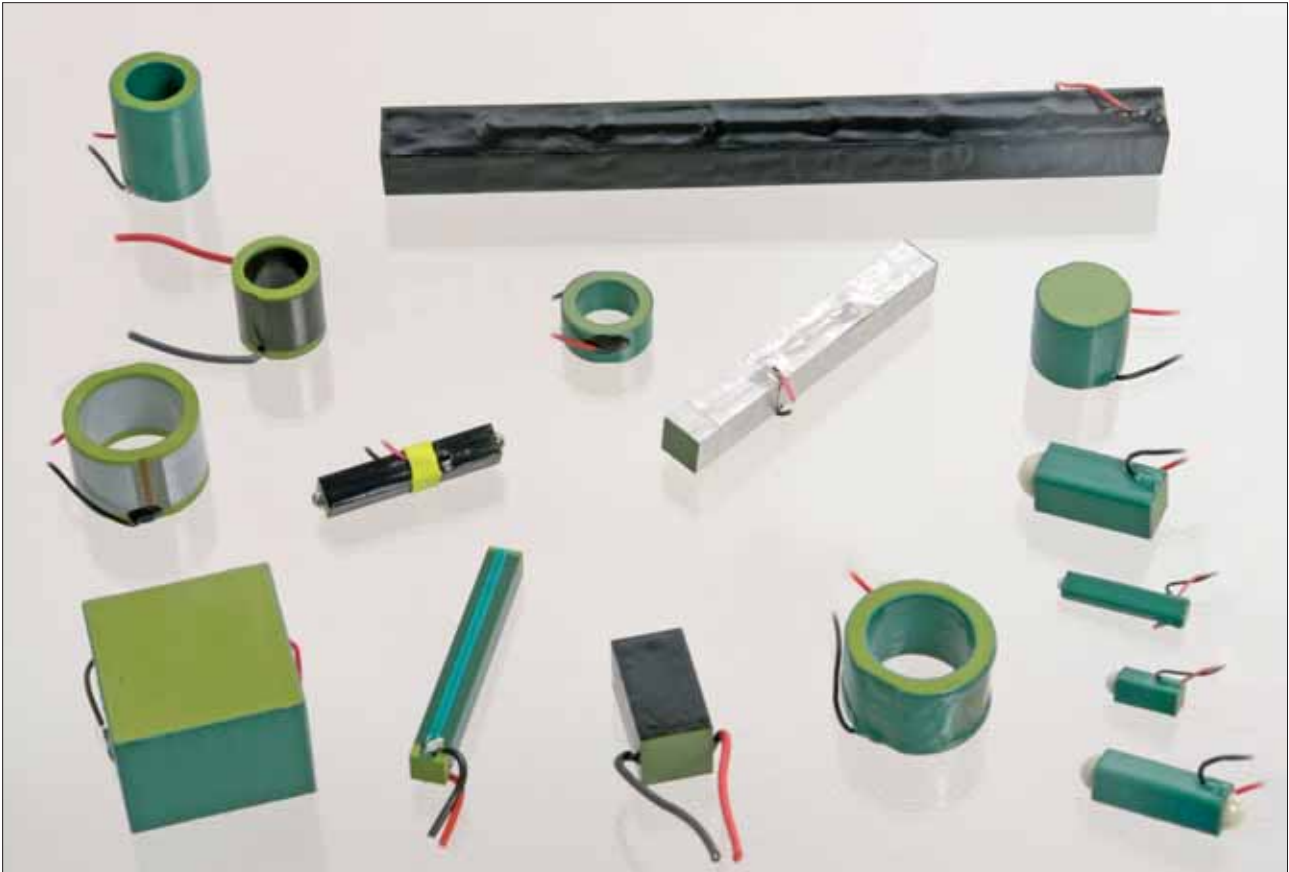

Fig. 21: Piezo-stacks PSt 150 and piezo-rings HPSt 150 in unsurpassed osi-technology

Top features:

- 100 % active PZT-ceramic (no inactive “dead zones” cross-section for maximum stroke and force generation
- Highly reliable and robust operation due to absence of intrinsic stress
- Low tilt operation
- Large cross-sections up to 25 x 25 mm
- High bending stability due to absence of interrupts/slots/cracks in the ceramic surface
- Large temperature range -273 °C up => +120 °C

- High quality polymer coating gives a robust finish and ruggedizes especially small cross-section elements.
- Adoption to exotic driving conditions
- Tight manufacturing tolerances

Suitable for a widest range of applications. Heat management allows very high dynamic operation

Ask PIEZOMECHANIK in case of special driving conditions

3.1 Piezo-stacks PSt 150/HPSt 150 (osi-type)

type osi-stack (+) U_{max} 150 V	ceramic- crosssection $a \times b / mm^2$	length L ¹⁾ mm	Max. Stroke ²⁾ μm	capacitance nF	Resonance frequency kHz	stiffness $N/\mu m$	Blockingforce ³⁾ N	Max. load force N
PSt 150/2x3/5	2 x 3	5	6.5/5	70	150	45	300	300
PSt 150/2x3/7	2 x 3	9	13/9	170	100	25	300	300
PSt 150/2x3/20	2 x 3	18	28/20	340	50	12	300	300
PSt 150/3.5x3.5/7	3.5 x 3.5	9	13/9	350	100	50	800	800
PSt 150/3.5x3.5/20	3.5 x 3.5	18	28/20	800	50	25	800	800
PSt 150/5x5/7	5 x 5	9	13/9	800	100	120	1600	2000
PSt 150/5x5/20	5 x 5	18	28/20	1800	50	60	1600	2000
PSt 150/7x7/7	7 x 7	9	13/9	1800	100	240	3500	4000
PSt 150/7x7/20	7 x 7	18	28/20	3600	50	120	3500	4000
PSt 150/10x10/7	10 x 10	9	13/9	3600	100	500	7000	8000
PSt 150/10x10/20	10 x 10	18	28/20	7200	50	250	7000	8000
PSt 150/14x14/20	14 x 14	18	28/20	14500	47	500	15000	16000
Ring-actuators (+) U_{max} 150 V	Diameters $a \times b$							
HPSt 150/14-10/12	14 x 10	13.5	16/12	2600	75	250	4500	7000
HPSt 150/20-15/12	20 x 15	13.5	16/12	5000	75	450	8000	12000

¹⁾ direction of expansion

²⁾ activation (-)30 V

³⁾ blocking force = max. force generation
defined for max. semi-bipolar operation

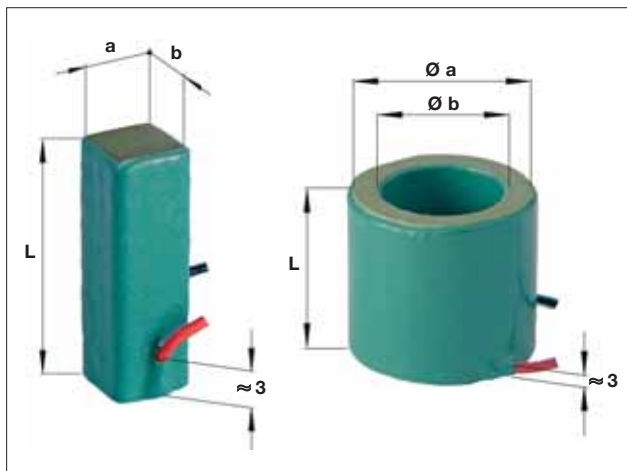

Fig. 22: Actuator PSt with standard coating

Dimensions

a , b , L refer to the ceramic structure,
Tolerances: +/- 0.03 mm

Maximum voltage range

(-)30 V/(+)150 V

3.1 Piezo-stacks PSt 150/HPSt 150 (osi-type)

Options

Position sensing by strain gages

Spherical end-pieces

(up to cross-sections 10 x 10 mm) (Fig. 23)

Low temperature operation

Cryo option 1: special coating

Cryo option 2: electrical contact by kapton-insulated Manganin wires for minimizing heat load

Temperature range

-273 °C thru approx. +120 °C (depends on coating, see below)

(beyond 100 °C, PZT-performance degrades reversibly)

Coatings

standard: high quality epoxy-based encapsulation
temperature range -50 °C thru +120 °C

vacuum/UHV grade thickness up to 0.5 mm

Special coatings optional eg. for cryo applications
thin coatings for stack packaging

(thickness < 50 µm)

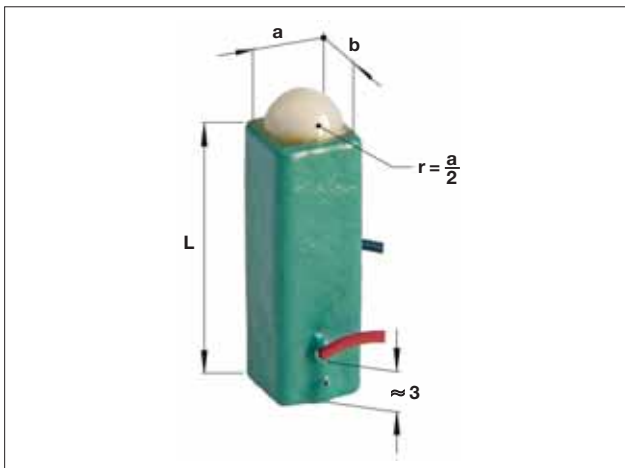

Fig. 23: Actor with spherical end-pieces

Extended to such actuators PSt. 150/axa/40 on request.

3.2 Piezostacks PSt 150 hTc with reduced capacitance (osi-type)

A new PZT-material is available in combination with the osi-stack technology.

The stacks are featuring reduced electrical capacitance and self-heating, when operated dynamically. These stacks are preferentially used for vibration excitation and dynamic positioning applications, where mainly high strain rates are required together with reduced force generation.

Typical applications are vibration generation equipments or scanners for optics, where power consumption and self-heating are a concern.

PSt 150hTc-stacks take up only 2/3 of the charging current to get the same dynamic motion profile compared to the standard PSt 150 stacks (see page 22).

Power dissipation is reduced equivalently resulting in a remarkably lower self-heating. Due to the higher Curie-temperature of this PZT-material, the stacks can be operated at higher temperatures without significant change in performance.

Comparison of important parameters between PSt 150 standard and the new PSt 150hTc piezo ceramics
(Voltage range (-)30V/(+)150V)

	PSt 150	PSt 150hTc
Charging current I <i>Sine 80 Hz/equal stroke, no force generation required</i>	100%	65% !
Self-heating <i>of a stack 10x10xL=18 mm/stroke 18 µm at 80 Hz/ambient air cooling</i>	60°	45° !
Curie temperatur	150 °C	200 °C
Electrical capacitance at room temperature <i>Example: stack 5x5xL = 18 mm</i>	100%	60%
	1,8 µF	1,05 µF
Electrical capacitance at 70 °C	135%	80%
Stroke <i>for equal voltage variation</i>	100%	90%
Blocking force <i>for equal voltage variation</i>	100%	75%

Operating temperature range of piezostacks PSt 150hTc:

Standard coating (green):

-50 °C thru +125 °C (long-term), 140 °C short-term

(Check page 22)

Cryo coating:

-273 °C thru +125 °C/140 °C

3.2 Piezostacks PSt 150 hTc with reduced capacitance (osi-type)

Product range: osi-stacks PSt 150hTc

PSt 150hTc/5x5/7	⇔	PSt 150/5x5/7
PSt 150hTc/3.5x3.5/18	⇔	PSt 150/3.5x3.5/20
PSt 150hTc/5x5/18	⇔	PSt 150/5x5/20
PSt 150hTc/7x7/18	⇔	PSt 150/7x7/20
PSt 150hTc/10x10/18	⇔	PSt 150/10x10/20
PSt 150hTc/14x14/18	⇔	PSt 150/14x14/20

Voltage range -30 V/+150 V

⇔ 100% compatibility of PSt 150 standard and PSt 150hTc stacks regarding outer dimensions, voltage range, coatings, options!

Longer stacks: on request

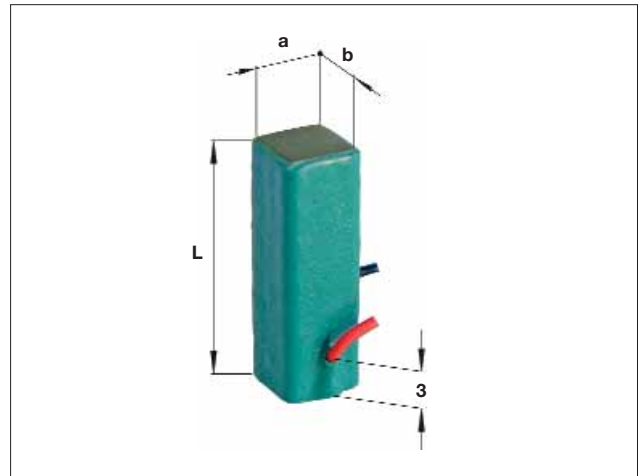

Fig. 24: piezo stack PSt 150hTc (dimensions see page 22)

Piezoactuator PSt 150hTc/.../... VS... with preloaded casing

(check main catalogue for standard)

Available types:

- PSt 150hTc/5/... VS10
- PSt 150hTc/7/... VS12
- PSt 150hTc/10/... VS15
- PSt 150hTc/14/... VS20
- PSt 150hTc/20/... VS25

Voltage range -30V/+150V

⇔ 100% compatibility of PSt 150 standard and PSt 150 hTc stacks regarding outer dimensions, voltage range, options!

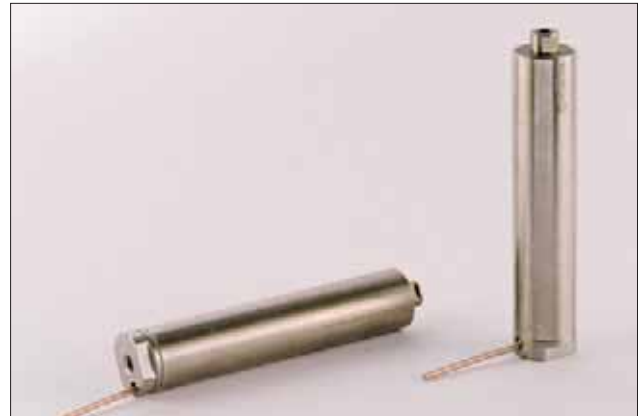

Fig. 25: piezo actuator with casing and internal preload, using PSt 150hTc (check also main catalogue)

3.3 Piezo-chips PCh 150 / HPCh 150 (isi-type)

Flat multilayer elements

- for ultra-compact actuator arrangements
- for high axial resonant frequencies
- suitable for d_{31} and d_{33} action
- for force sensing/generator application
- special 50 V-type with very high charge generation rate

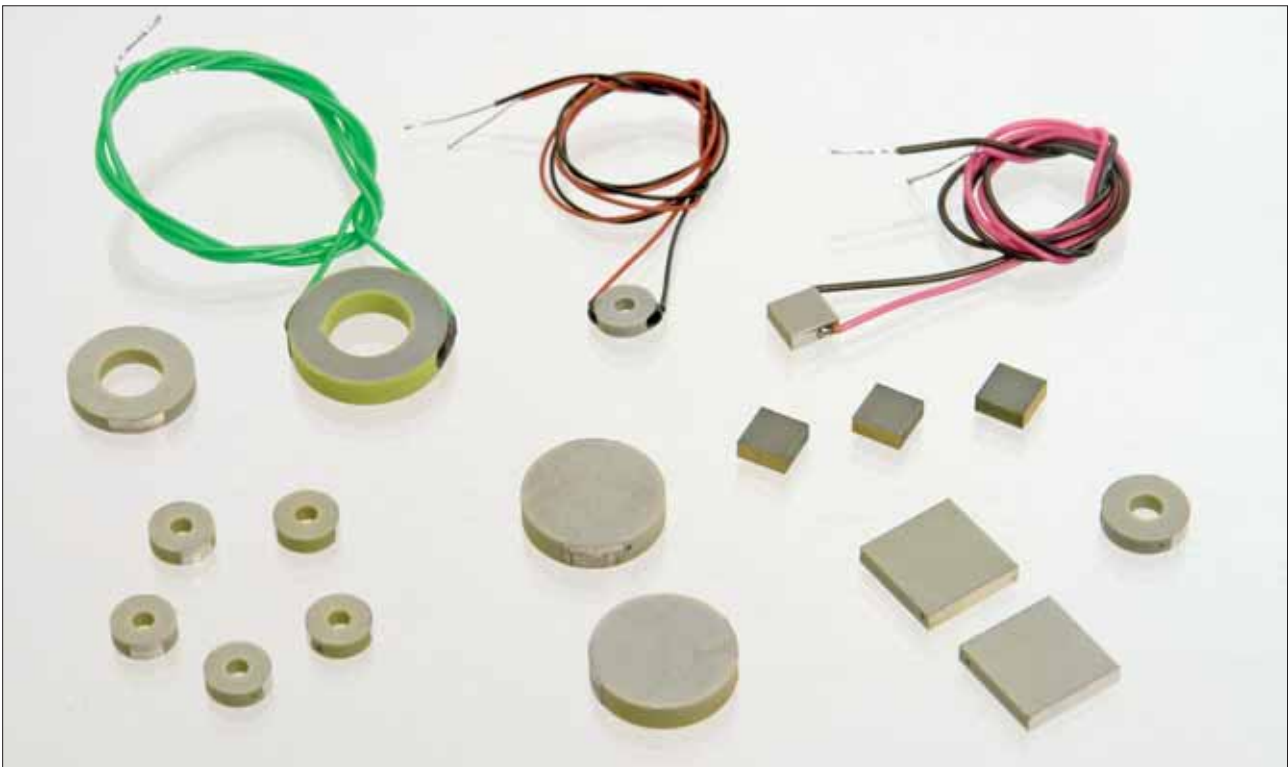

Fig. 26: Piezo-chips

Actor type isi-Stacks	Ceramic crosssection $a \times b / \text{mm}^2$	thickness L ¹⁾ mm	Max. Stroke ²⁾ μm	capacitance nF	Resonance- frequency kHz	stiffness $\text{N}/\mu\text{m}$	Blockingforce ³⁾ N	Max. load force N
(+) U_{max} 50 V								
PCh 50/5x5/2	5x5	2	>3/>2	1250	> 500 kHz	500	1500	2000
(+) U_{max} 150 V								
PCh 150/3x3/2	3x3	2	>3/>2	30	>500 kHz	190	500	500
PCh 150/5x5/2	5x5	2	>3/>2	110	>500 kHz	500	1500	2000
PCh 150/7x7/2	7x7	2	>3/>2	240	>500 kHz	1000	3000	5000
PCh 150/10x10/2	10x10	2	>3/>2	480	>500 kHz	1900	6000	10000
Ring-actuators								
(+) U_{max} 150 V		Diameters $a \times b$						
HPCh 150/6-2/2	6x2	2	>3/>2	110	>500 kHz	400	1500	2000
HPCh 150/8-3/2	8x3	2	>3/>2	200	>500 kHz	900	2500	4000
HPCh 150/12-6/2	12x6	2	>3/>2	500	>500 kHz	1400	5000	5000
HPCh 150/15-8/3	15x8	3	>4/>3	790	>300 kHz	1800	7000	10000

¹⁾ direction of expansion

²⁾ semi-bipolar/unipolar activation

³⁾ blocking force = max. force generation defined for max. semi-bipolar operation

3.3 Piezo-chips PCh 150/HPCh 150 (isi-type)

Dimensions

a, b, L

tolerances:

a, b +/- 0.3 mm

L +/- 0.1 mm

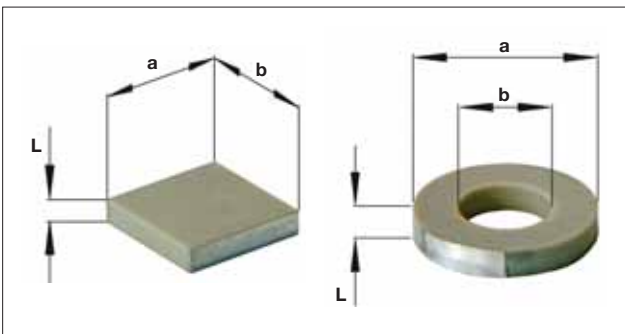

Fig. 27: Piezo-chips PCh, PHCh

Maximum voltage ranges

PCh 50: (-)10 V/(+)50 V

PCh 150: (-)30 V/(+)150 V

Temperature range

-273 °C thru approx. +130 °C

Surface insulation

buried electrode, no coating

Mounting advises: Piezo-chips show very small stroke rates due to their short active length L.

Incorrect mounting will impact force and stroke generation, leading to insufficient performance and unwanted bending and tilting. Please follow instructions in chapter 2.3.

3.4 Special designed stacks and rings

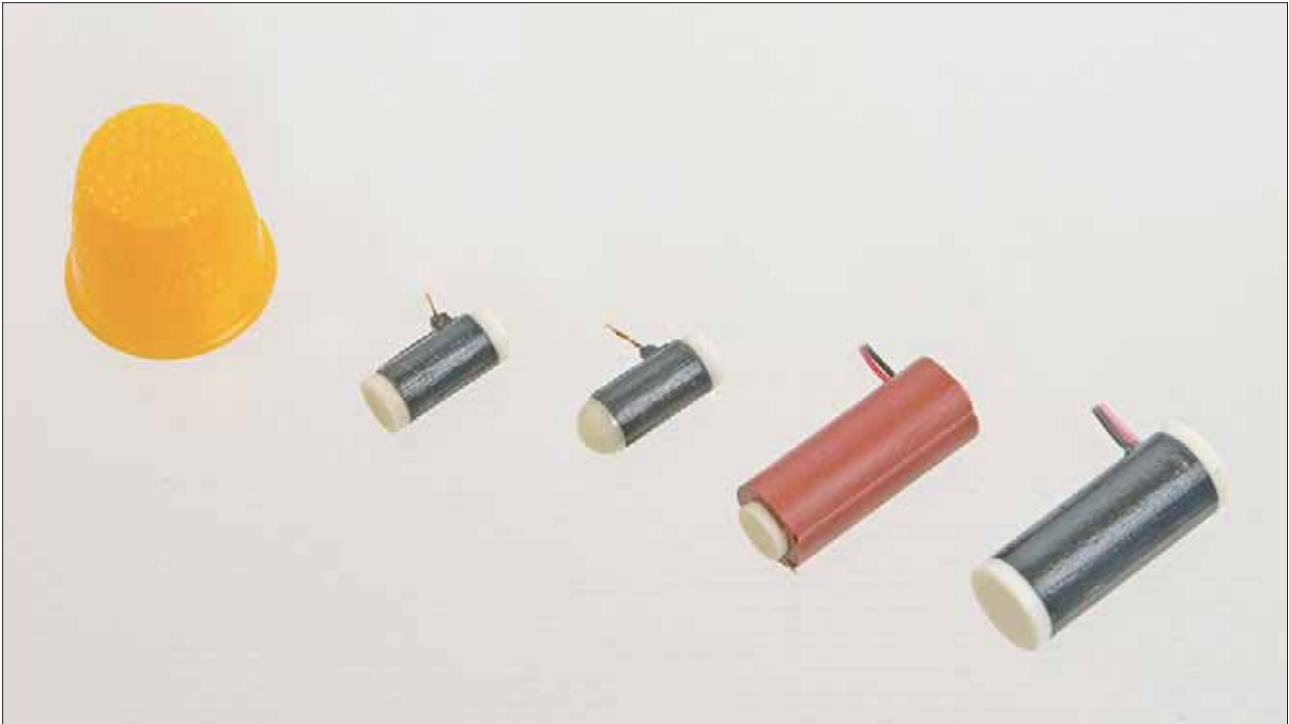

Fig. 28: Special designed stacks and rings

On request, PIEZOMECHANIK delivers special designed stack and rings:

- With regard to length, cross-section (squaric, rectangular, cylinders)
- Voltage ranges
- Finish (optional end-pieces, mechanical couplers)

Piezomechanik · Dr. Lutz Pickelmann GmbH

Berg-am-Laim-Str. 64 · D-81673 Munich · Phone ++ 49/89/46 1467 96 · Fax ++ 49/89/4 31 64 12
e-mail: info@piezomechanik.com · <http://www.piezomechanik.com>

